

EMS: Care of the VAD Patient

Brittany Butzler BSN RN

VAD Coordinator

Froedtert and the Medical College of WI

Disclosure

- No relevant financial relationships by planners or presenters

Left Ventricular Assist Device-LVAD

- Surgically implanted mechanical pump that assists the left ventricle for patients with advanced heart failure.
- Continuous flow technology, patients will likely **NOT have a pulse** and pulse oximetry may be difficult to obtain.
- Must obtain MAP blood pressures
 - Normal Range: 60-80mmHg
 - Some patients are pulsatile or have native contractility, if you can feel a pulse you can obtain a 'normal' blood pressure.
- Requires two power connections to power controller and pump. Likely will be on two batteries for transport.
- Patient has a driveline that extends out of the abdomen that connects to the controller. If this is removed, the pump will stop.

Survival Rates with VADs

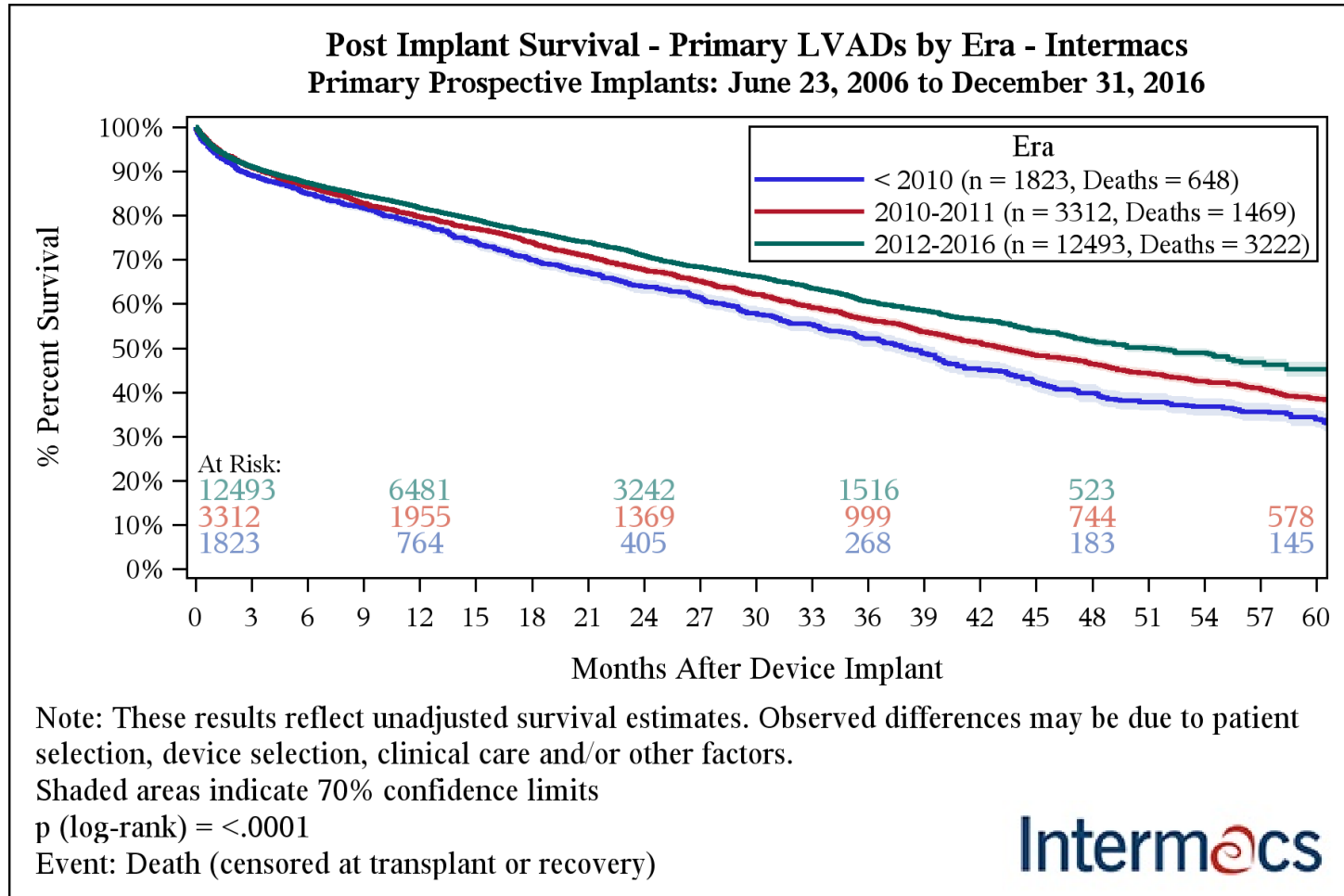

Indications for Use

- Bridge to Heart Transplant (BTT)
 - Candidate for cardiac transplantation
- Destination Therapy (DT)
 - Patient does not meet selection criteria for cardiac transplantation
 - Patient will have this device lifelong

Heartmate II

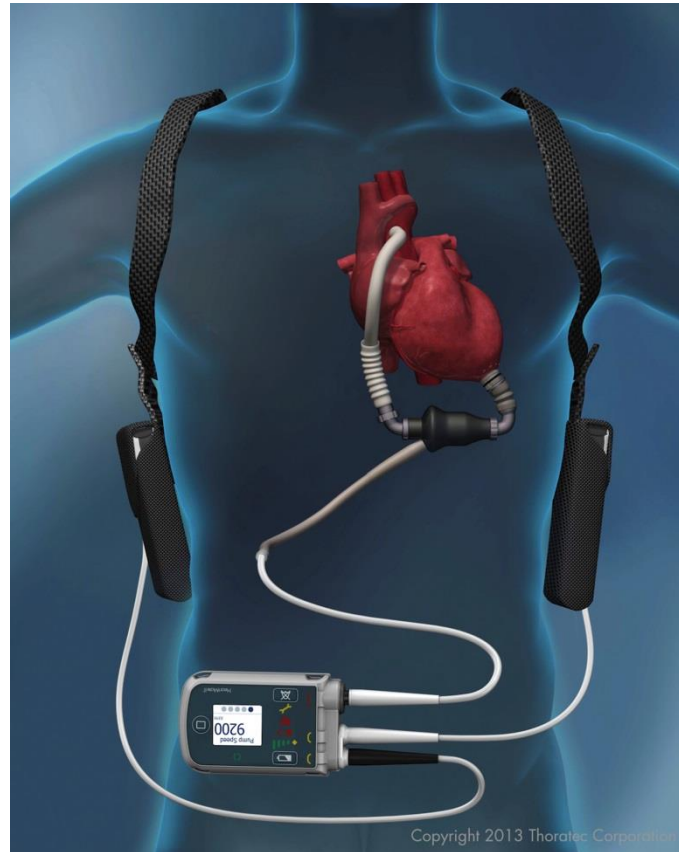

Copyright 2013 Thoratec Corporation

Heartmate II

- FDA approved for BTT and DT
- May see two different controllers
 - Pocket Controller (newer model)
 - Display screen
 - EPC (older model)
 - No display screen
 - Powered by two external batteries or small mobile power unit
 - Backup battery inside controller
- Axial Flow
 - More shear stress from propeller blades on blood

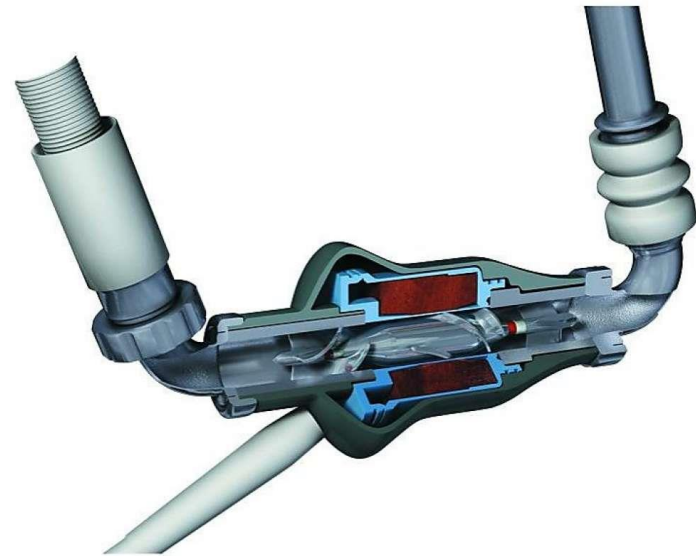

Copyright 2007 Thoratec Corporation

Heartmate 3

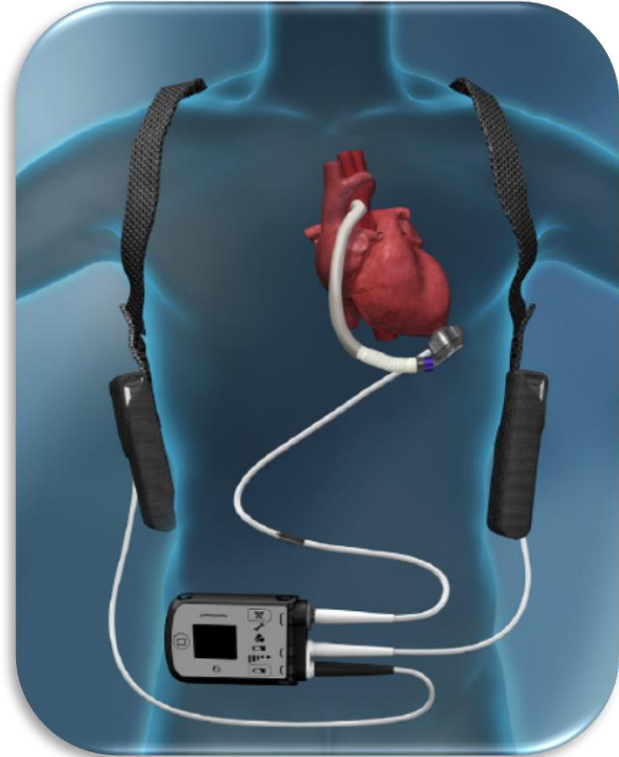

Heartmate 3

- Recently FDA approved for BTT
- Powered by two external batteries or small mobile power unit
- Backup battery inside controller
- Centrifugal flow
 - Hemodynamic bearings

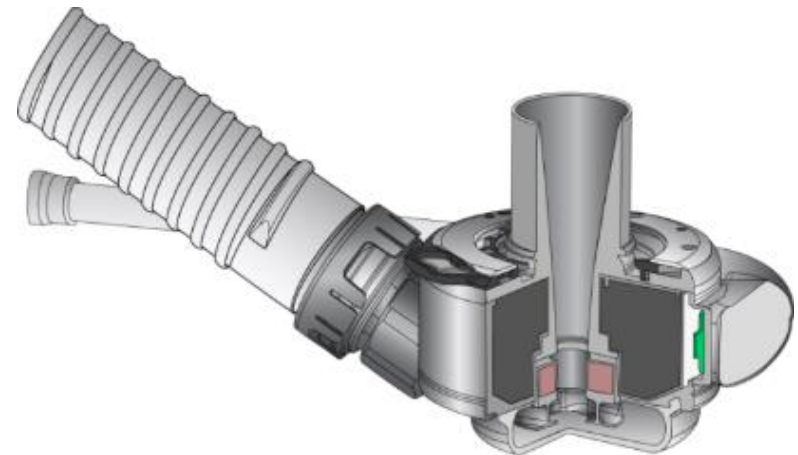

Heartmate II/3 System Components



EPC Controller



HMII Pocket controller



HM3 Pocket controller



Power Module



MPU (mobile power unit)



Battery Charger and Batteries

Heartware

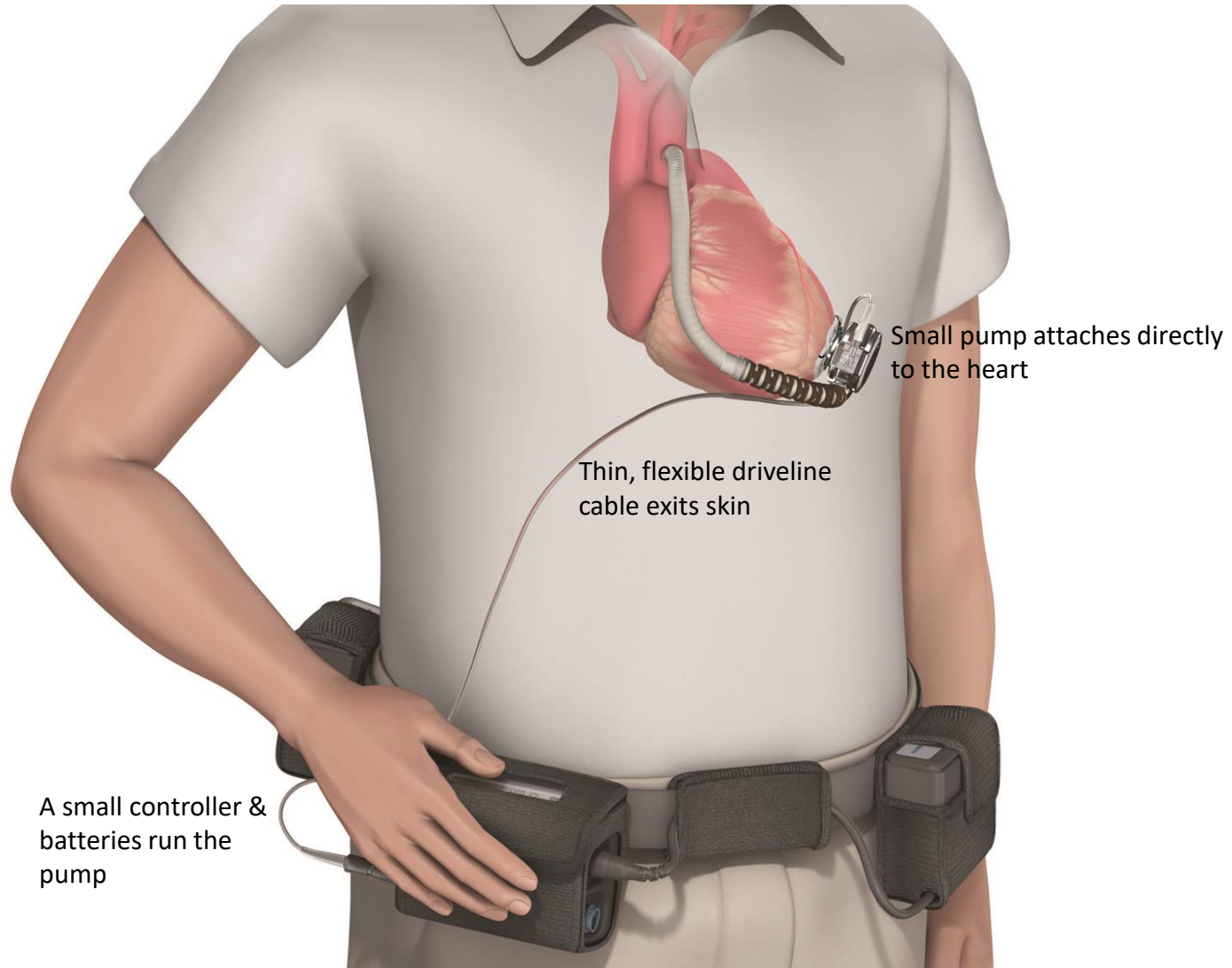

Heartware

- FDA approved for BTT, currently completing trial to become DT
- Display screen with pump parameters
- Powered by two external batteries or AC (wall) plug.
- Centrifugal flow
 - Rotating element is a spinning disc



Heartware System Components

- HeartWare® Controller: Controls and manages VAD operation



- HeartWare® Power Sources: Power the controller and pump
 - Batteries
 - AC adapter (plugs into wall outlet)
 - DC adapter (plugs into car outlet)



- HeartWare® Battery Charger: Can simultaneously charge up to 4 batteries



Pump Parameters

- Flow
 - Amount of blood flowing through the VAD
 - Displayed as L/min
 - Calculated value based on speed
 - Fluctuations are normal
- Speed
 - How fast the VAD is moving/rotating
 - Displayed by RPMs
 - Fixed speed set by VAD team
 - Heartmate may fluctuate 150 RPMs
 - Heartware should remain fixed
- Power
 - Energy required at a given speed
 - Displayed in Watts
 - Fluctuations are normal

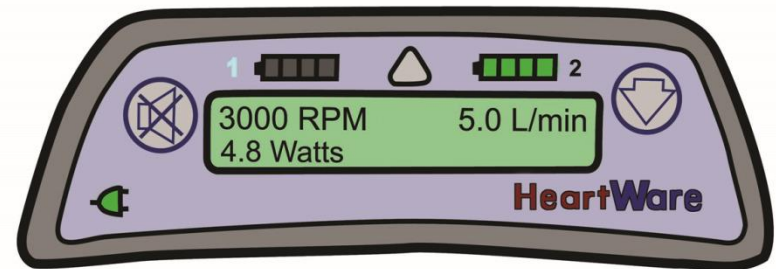

Alarms

- Heartware
 - Will appear on controller display
 - Will have associated 'yellow' or 'red' display light
- Heartmate
 - Pocket Controller : will appear on controller display
 - EPC: no controller display, will have associated 'yellow' or 'red heart' display light
- Red alarms are the most serious alarms.

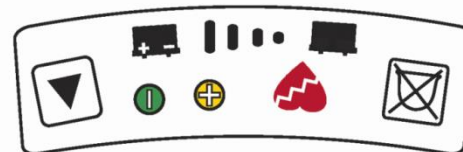

Driveline

- Driveline consists of a single cable that extends from the pump through the skin to the controller.
- Driveline contains six wires-three primary wires and three backup wires.
- To prevent infection, the driveline is covered with woven polyester which encourages tissue ingrowth at the skin line. Over time, tissue bonds to the textured material and anchors the external surface of the driveline to the surrounding tissue.

Anticoagulation

- Typically a combination of warfarin and aspirin.
- Goal INR 2-3

Doppler MAP

- Need to obtain doppler MAP due to continuous blood flow.
- You will usually hear 1 number, this is the mean arterial pressure (MAP)
- MAPs should be between 60-80mmHg
- Automated BPs will not always be accurate.
 - If you can feel a radial pulse, try obtaining an automated cuff pressure



Long Term Complications

- 1 in 10 patients will experience a stroke
- 2 in 10 patients will develop device related infection.
 - Typically, driveline site infections
 - Caregivers are taught how to complete a daily sterile dressing change
- 2-3 in 10 patients will bleed
- 1% of patients will require a pump replacement either from thrombus or infection

Acute Complications

- Hypovolemia
 - LVADs are preload dependent and afterload sensitive.
 - Patient could be having a low flow or a suction alarm
- Hemorrhage
- Ischemic Stroke
- Infection/Sepsis
- Pump Thrombus
 - Can be located in multiple areas of pump and will affect pump parameters based on location of thrombus
 - Diagnosis includes labs, UA, echo and/or CT angio
- RV Dysfunction
 - Typically immediately post operative
 - Management: temporary mechanical RV support, inotropes, lowering LVAD speed and volume management

When you are called for a VAD patient, please do the following:

- In most cases, the patient or caregiver has already talked to the VAD team. They should be able to tell you their normal parameters.
 - Involve VAD team in patient management decisions
- If the patient is unconscious, make sure you bring their back-up controller and extra batteries to the hospital.
- If VAD is alarming, make sure you check all connections, make sure batteries are charged and connected tightly.
- Alarms will be displayed on controller display

Controller Exchange

- If the pump is alarming with a red high priority alarm, the patient or caregiver will have to change to their back up controller.
- If a controller exchange is needed, the patient and caregiver are trained to do so.
- This involves removing the driveline from the controller, which powers the pump.
- This is done in emergency situations only and needs to be done as fast as possible.
- If the controller has been alarming with no power to the pump for an unknown period of time, the patient should NOT change their controller and be taken to the hospital immediately.
 - In this circumstance, we do not know how long the pump has been off. In that time, blood is pooling around the motor of the pump. If it is restarted they are at risk of throwing a clot.

- Our VAD team has 24 hour coverage. The patients will know this number and they will have a label on top of their controller with the hospital access center number:

414-805-6700.

- State you are with a VAD patient and you need to speak to the VAD team.
- Follow ACLS protocol if needed
 - Do not need to disconnect anything from LVAD
- Most of our patients have an AICD
- If patient is having a ‘low flow’ alarm, they may be dehydrated.
 - Pumps are volume dependent
 - May start IVF
- Always make sure the patient has their backup controller and two extra batteries with them at all times.
- If the situation is not cardiac, treat them like a normal patient
- Our patients are typically overprotective of their pump, they will tell you what to do.

References

- Heartware Ventricular Assist Device: Instructions for Use
- Heartmate II Left Ventricular Assist System (LVAS): Instructions for Use
- Heartmate 3 Left Ventricular Assist System (LVAS): Instructions for Use
- ISHLT Website